

FilterPro™ MFB and Sallen-Key Low-Pass Filter Design Program

John Bishop, Bruce Trump, R. Mark Stitt

Op-Amp Applications, High Performance Linear Products

ABSTRACT

Although low-pass filters are vital in modern electronics, their design and verification can be tedious and time consuming. The *FilterPro* program is designed to aid in the design of low-pass filters implemented with the multiple feedback (MFB) and Sallen-Key topology. This note serves as an operator's manual for *FilterPro*. Among other issues, it describes the information the designer must enter into the program and what the program delivers.

Contents

FilterPro Low-Pass Filter Design Program	2
Butterworth (maximally flat magnitude).....	3
Chebyshev (equal ripple magnitude).....	3
Bessel (maximally flat time delay).....	3
Summary	5
Butterworth Response.....	5
Chebyshev Response	5
Bessel Response	5
Circuit Implementation.....	6
MFB Topology.....	6
Sallen-Key Topology	7
Using the FilterPro Program.....	7
Computer Requirements.....	7
Installation	7
Getting Started.....	7
Program Features.....	9
To Print Results	9
Sensitivity.....	9
fn Sensitivity for Both MFB and Sallen-Key	9
Q Sensitivity	9
Using the Sensitivity Display Feature	10
Using the Speed Resistor Setting.....	10
Capacitor Values.....	11
Compensate for Op Amp Input Capacitance—Sallen-Key Only	11
Capacitor Selection.....	11
Using the fn and Q Display	12
Op Amp Selection.....	12
Op Amp Bandwidth.....	12
Op Amp Slew Rate	12
The UAF42 Universal Active Filter	13

Current Feedback Amplifiers.....	13
Fully Differential Amplifiers	13
Examples of MFB Filter Response	14
Conclusion.....	15

Figures

Figure 1. Response vs Frequency of Even-Order (4-pole), 3dB Ripple Chebychev Filter Showing Cutoff at 0 dB.....	4
Figure 2. Response vs. Frequency of Even-Order (5-pole), 3dB Ripple Chebychev Filter Showing Cutoff at -3 dB.....	4
Figure 3. Real Pole Section (Unity-Gain, First-Order Butterworth; $f_{-3dB} = 1/2 \cdot \pi \cdot R_1 \cdot C_1$)	4
Figure 4. Second-Order Low-Pass Filter.	4
Figure 5. Third-Order Low-Pass Filter.	4
Figure 6. Even-Order Low-Pass Filter Using Cascaded Complex Pole-Pair Sections.	5
Figure 7. Odd-Order Low-Pass Filter Using Cascaded Complex Pole-Pair Sections Plus One Real-Pole Section.....	5
Figure 8. MFB Complex Pole-Pair Section. (Gain = $-R_2/R_1$).....	6
Figure 9. Sallen-Key Complex Pole-Pair Section. (Gain = 1) Unity Gain	6
Figure 10. Sallen-Key Complex Pole-Pair Section. (Gain = $1 + R_4/R_3$).....	6
Figure 11. Screen Display of <i>FilterPro</i> Showing a 9 Pole MFB Filter With a Gain of 40 dB.	8
Figure 12. Third-Order Low-Pass Filter Driving an ADC	13
Figure 13. Gain vs Frequency for Fifth-Order 20kHz Butterworth, Chebyshev, and Bessel Unity-Gain MFB Low-Pass Filters, Showing Overall Filter Response.....	14
Figure 14. Gain vs Frequency for Fifth-Order 20kHz Butterworth, Chebyshev, and Bessel Unity-Gain MFB Low-Pass Filters, Showing Transition-Band Detail.....	14
Figure 15. Step Response of Fifth-Order 20 kHz Butterworth Low-Pass MFB Filter.....	14
Figure 16. Step Response of Fifth-Order 20 kHz Chebyshev Low-Pass MFB Filter.....	14
Figure 17. Step Response of Fifth-Order 20 kHz Bessel Low-Pass MFB Filter.	15
Figure 18. Measured Distortion for the Three 20 kHz MFB Low-Pass Filters.	15

Tables

Table 1. Filter Circuit vs. Filter Order	6
--	---

FilterPro Low-Pass Filter Design Program

The Texas Instruments *FilterPro* program makes it easy to design low-pass active filters. The program aids in the design of low-pass filters implemented with the Multiple Feedback (MFB) topology. Because there are instances where the Sallen-Key filter topology is a better choice, the program also supports Sallen-Key low-pass filter design.

An ideal low-pass filter would completely eliminate signals above the cutoff frequency, and perfectly pass signals below cutoff (in the pass-band). In real filters, various tradeoffs are made attempting to approximate the ideal. Some filter types are optimized for gain flatness in the pass-band, some trade off gain variation (ripple) in the pass-band for steeper roll-off, still others trade off both flatness and rate of rolloff in favor of pulse-response fidelity. *FilterPro* supports the three most commonly-used all-pole filter types: Butterworth, Chebyshev, and Bessel.

Butterworth (maximally flat magnitude)

This filter has the flattest possible pass-band magnitude response. Attenuation is -3 dB at the design cutoff frequency. Attenuation above the cutoff frequency is a moderately steep 20-dB per decade per pole. The pulse response of the Butterworth filter has moderate overshoot and ringing.

Chebyshev (equal ripple magnitude)

Note: Mr. Chebyshev's name is also transliterated Tschebychev, Tschebyscheff or Tchevysheff. This filter type has steeper attenuation above the cutoff frequency than Butterworth. This advantage comes at the penalty of amplitude variation (ripple) in the passband. Unlike Butterworth and Bessel responses, which have 3-dB attenuation at the cutoff frequency, Chebyshev cutoff frequency is defined as the frequency at which the response falls below the ripple band. For even-order filters, all ripple is above the 0-dB-gain dc response, so cutoff is at 0-dB (see Figure 1.) For odd-order filters, all ripple is below the 0-dB-gain dc response, so cutoff is at $-(\text{ripple})$ dB (see Figure 2.) For a given number of poles, a steeper cutoff can be achieved by allowing more pass-band ripple. The Chebyshev has even more ringing in its pulse response than the Butterworth.

Bessel (maximally flat time delay)

(Also called Thomson.) Due to its linear phase response, this filter has excellent pulse response (minimal overshoot and ringing). For a given number of poles, its magnitude response is not as flat, nor is its attenuation beyond the -3 -dB cutoff frequency as steep as the Butterworth. Although it takes a higher-order Bessel filter to give a magnitude response which approaches that of a given Butterworth filter, the pulse response fidelity of the Bessel filter may make the added complexity (because of additional filter sections) worthwhile.

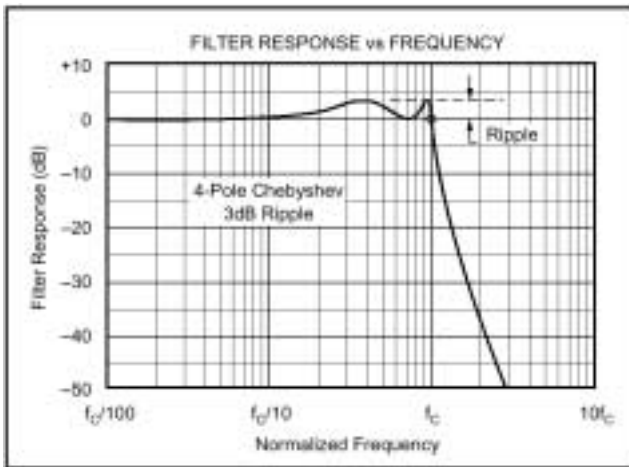

Figure 1. Response vs Frequency of Even-Order (4-pole), 3 dB Ripple Chebyshev Filter Showing Cutoff at 0 dB.

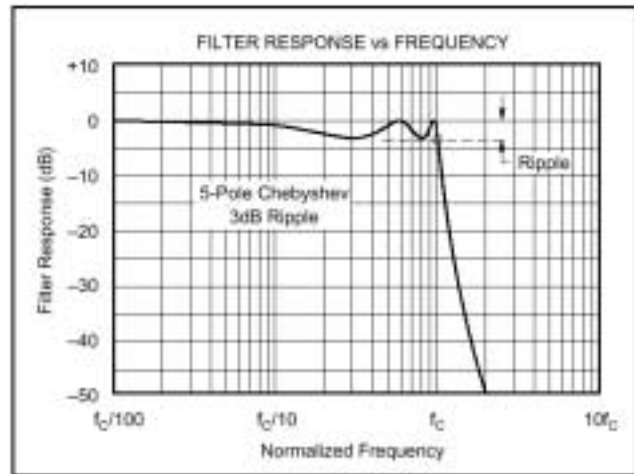

Figure 2. Response vs. Frequency of Even-Order (5-pole), 3 dB Ripple Chebyshev Filter Showing Cutoff at -3 dB

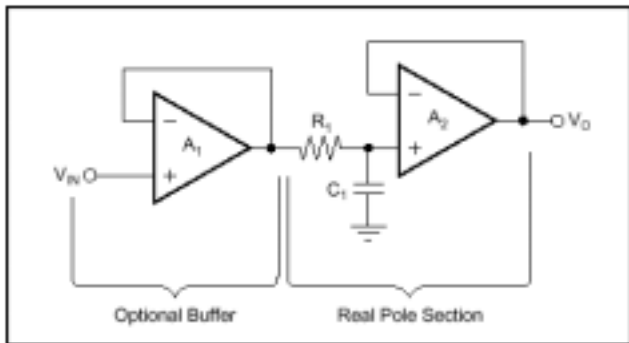

Figure 3. Real Pole Section (Unity-Gain, First-Order Butterworth; $f_{-3dB} = 1/2 \cdot \pi \cdot R1 \cdot C1$)

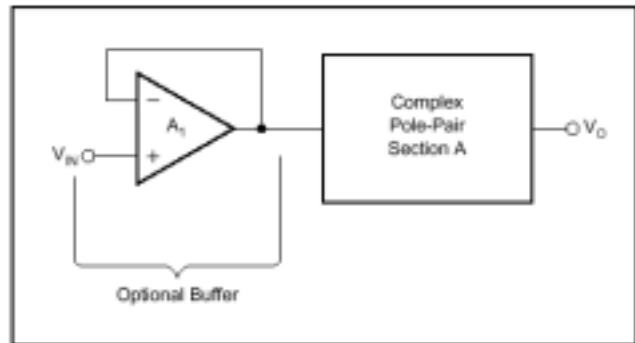

Figure 4. Second-Order Low-Pass Filter.

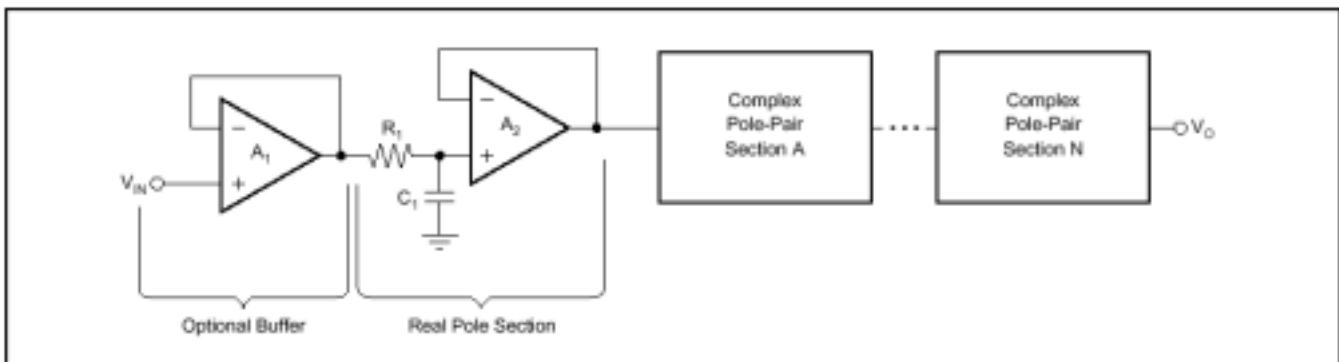

Figure 5. Third-Order Low-Pass Filter.

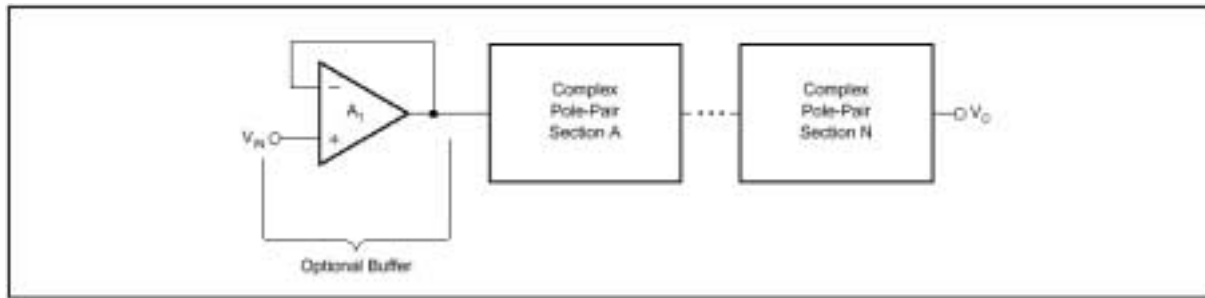

Figure 6. Even-Order Low-Pass Filter Using Cascaded Complex Pole-Pair Sections.

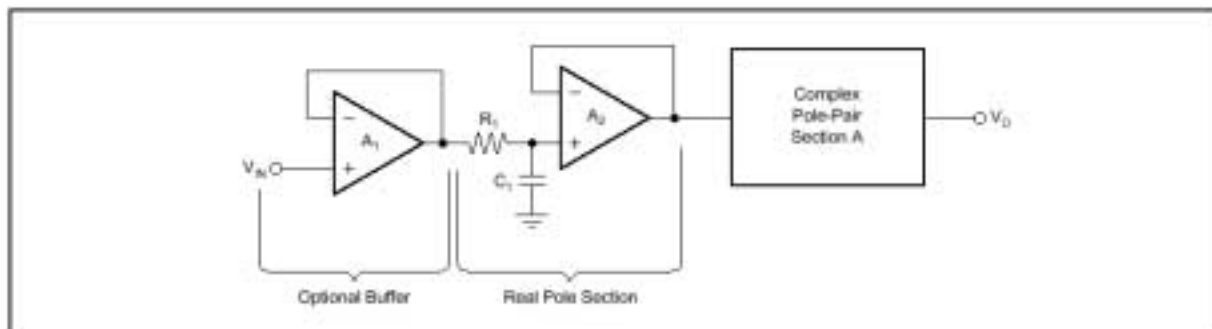

Figure 7. Odd-Order Low-Pass Filter Using Cascaded Complex Pole-Pair Sections Plus One Real-Pole Section.

Summary

Butterworth Response

Advantages: It provides maximally flat magnitude response in the pass-band. It has good all-around performance. Its pulse response is better than Chebyshev. Its rate of attenuation is better than that of Bessel.

Disadvantages: Some overshoot and ringing is exhibited in step response.

Chebyshev Response

Advantages: It provides better attenuation beyond the pass-band than Butterworth.

Disadvantages: Ripple in pass-band may be objectionable. There is considerable ringing in step response.

Bessel Response

Advantages: It provides best step response: very little overshoot or ringing.

Disadvantages: It exhibits slower rate of attenuation beyond the pass-band than Butterworth.

Circuit Implementation

Even-order filters designed with this program consist of cascaded sections of complex pole-pairs. Odd-order filters contain an additional real-pole section. Figures 3 through 7 show the recommended cascading arrangement. The figures show the additional real-pole section ahead of the other sections, but some configurations are better with the real-pole section following (see Figure 12). The program automatically places lower Q stages ahead of higher Q stages to prevent op amp output saturation due to gain peaking. The program can be used to design filters up to 10th order.

FILTER ORDER	FIGURE
1 pole	Figure 3
2 poles	Figure 4
3 poles	Figure 5
4 or more poles (even order)	Figure 6
5 or more poles (odd poles)	Figure 7

Table 1. Filter Circuit vs Filter Order

Complex Pole-Pair Circuit

The choice of a complex pole-pair circuit depends on performance requirements. *FilterPro* supports the two most commonly used active pole-pair circuit topologies:

- Multiple Feedback (MFB)—shown in Figure 8.
- Sallen-Key—shown in Figures 9 and 10.

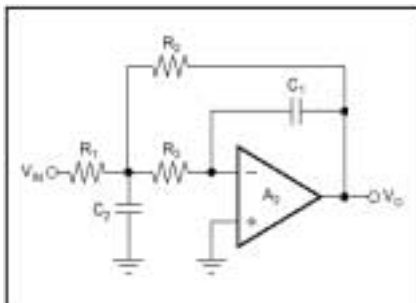

Figure 8. MFB Complex Pole-Pair Section. (Gain = $-R_2/R_1$)

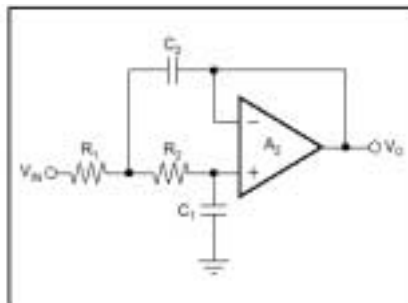

Figure 9. Sallen-Key Complex Pole-Pair Section. (Gain = 1) Unity Gain

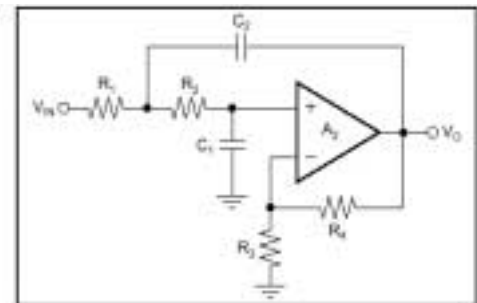

Figure 10. Sallen-Key Complex Pole-Pair Section. (Gain = $1 + R_4/R_3$)

MFB Topology

The MFB topology (sometimes called Infinite Gain or Rauch) is often preferred due to assured low sensitivity to component variations—see sensitivity section.

Sallen-Key Topology

There are instances where the Sallen-Key topology is a better choice. As a rule of thumb, the Sallen-Key topology is better if:

- 1) Gain accuracy is important, *and*
- 2) A unity-gain filter is used, *and*
- 3) Pole-pair Q is low (e.g., $Q < 3$)

At unity-gain, the Sallen-Key topology inherently has excellent gain accuracy. This is because the op amp is used as a unity-gain buffer. With the MFB topology, gain is determined by the R_2/R_1 resistor ratio. The unity-gain Sallen-Key topology also requires fewer components—two resistors vs three for MFB.

The Sallen-Key topology may also be preferable for high-Q high frequency filter sections. In these sections, the value required for C_1 in an MFB design can be quite low for reasonable resistor values. Low capacitor values can result in significant errors due to parasitic capacitance.

The best filter design may be a combination of MFB and Sallen-Key sections. To do this, use FilterPro to define the component values of the same design using both circuit types and then use some of the sections from one design with some from the other design to build your filter design.

Using the *FilterPro* Program

With each data entry, the program automatically calculates filter performance and values for all filter components. This allows you to use a *what if* spreadsheet-type design approach. For example, you can quickly determine, by trial and error, how many poles are needed for a given rolloff.

Computer Requirements

The operating system required for *FilterPro* for windows should be Windows 95 or NT 3.5 or newer. The display should be configured for at least 800 by 600. It is helpful, but not required, to have a printer (capable of printing a screen dump) available, either locally or on a network.

Installation

To install *FilterPro* on your computer, run the setup.exe program from the hard disk or CD.

Getting Started

The first time you use the program, you may want to double click on the FilterPro icon on the desktop. Another way is to select Start, Programs, and FilterPro. At this point, you have already designed a 3-pole, 1-kHz Butterworth filter. Component values are shown on the schematic. For a different filter design, click on the radio buttons for one of the following options. On-screen prompts, to the left of the response graph, will guide your program use. Refer to this bulletin for more detail, if needed. All settings required are inside the Settings frame.

- 1) In the Circuit Type frame, choose pole-pair circuit: MFB or Sallen-Key
- 2) In the Filter Type frame, select Filter type: Butterworth, Chebyshev or Bessel.

- 3) For the Chebyshev filter type, enter ripple amount: 0.0001 dB to 10 dB
- 4) Enter the desired number of poles: 1 to 10 (2 min. for Bessel or Chebychev)
- 5) Enter the filter cutoff frequency: 1 mHz to 100 MHz
- 6) If you want to view the gain/phase response of the current filter design at a particular frequency (the default value is 10 times the cutoff frequency), enter the frequency of interest on the response entry box. The gain/phase values are displayed on the f_n , Q , $Response$ display fields.
- 7) If you want to change the resistor scaling, enter a value on the R1 Seed entry. This will also change the capacitor values accordingly.
- 8) If you want to change the gain of a section, enter the desired value into the appropriate gain entry box. Default value for gain is 1.0-V/V in each section.
- 9) If you want to enter your own capacitor values, enter them into the appropriate C1 or C2 entry boxes. This will cause the seed resistor entry to be ignored.
- 10) If you want to design with standard 1% resistors instead of exact resistors, click the 1% Resistors check box.

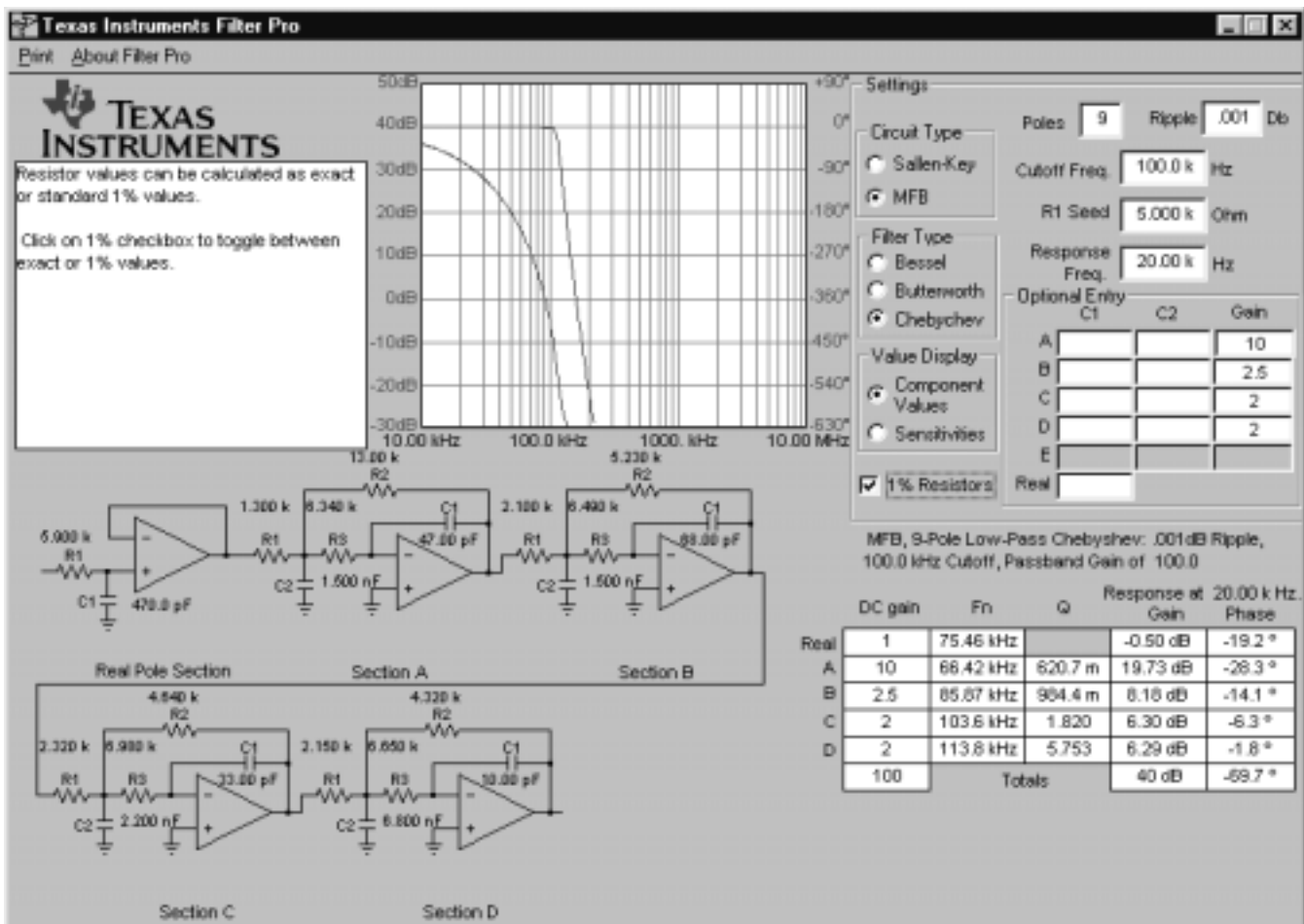

Figure 11. Screen Display of FilterPro Showing a 9 Pole MFB Filter With a Gain of 40 dB.

Program Features

To Print Results

To print results select the Print menu item. It displays a dialog box that can be used to print the screen. When printing is started, the normal screen size increases to include a table containing information not shown on the schematic (sensitivity data or component values). The larger screen is then captured and sent to the printer. If the screen is not fully visible, due to position or size, only what is visible is printed.

Sensitivity

Sensitivity is the measure of the vulnerability of a filter's performance to changes in component values. The important filter parameters to consider are natural frequency (f_n) and Q.

f_n Sensitivity for Both MFB and Sallen-Key

Sensitivity of f_n to resistor, capacitor, and amplifier gain variations is always low for both the Sallen-Key and MFB filter topologies.

$$S_R^f = S_C^f = \pm 0.5\% / \%$$

$$S_K^f = 0$$

where:

S_R^f, S_C^f, S_K^f = Sensitivity of f_n to resistor, capacitor, and gain variations

Q Sensitivity

For the MFB topology, sensitivities to Q are also always low, but sensitivities for the Sallen-Key topology can be quite high—exceeding $2 \cdot K \cdot Q^2$. K is the variable used here for gain. At unity gain, the Sallen-Key Q sensitivity to resistor and capacitor variations is always low. Unfortunately, however, the sensitivity of the unity-gain Sallen-Key pole-pair to op amp gain can be high.

Q Sensitivity for MFB Pole-Pair

$$S_C^Q = \pm 0.5\% / \%$$

$$S_R^Q = \pm \frac{R_2 - R_3 - K \cdot R_3}{2(R_2 + R_3 + K \cdot R_3)} \quad (\text{MFB complex pole-pair})$$

$$S_K^Q = \pm \frac{K \cdot R_3}{R_2 + R_3 + K \cdot R_3} \quad (\text{MFB complex pole-pair})$$

Notice, by inspection: S_R^Q is always less than $\pm 0.5\% / \%$, and S_K^Q is always less than $1.0\% / \%$.

Q Sensitivity for Gain = 1 Sallen-Key Pole-Pair

$$S_C^Q = \pm 0.5\% / \%$$

$$S_R^Q = \pm \frac{R_1 - R_2}{2(R_1 + R_2)} \quad (\text{Sallen-Key complex pole-pair})$$

So, S_R^Q is always less than $\pm 0.5\% / \%$.

$$S^2 < S_K^Q < 2 \cdot Q^2 S \quad (\text{Sallen-Key complex pole-pair})$$

where:

S_R^Q, S_C^Q, S_K^Q = Sensitivity of f_n and Q to resistor, capacitor and gain variations (%/%)

K = Op amp gain (V/V)

Figure 8 circuit, $K=R_2/R_1$

Figure 9 circuit, $K=1.0$

Figure 10 circuit $K=1+R_4/R_3$

NOTE: *FilterPro* always selects component values so unity-gain Sallen-Key S_K^Q will be closer to Q^2 than to $2 \cdot Q^2$. However, it will allow you to design Sallen-Key pole-pairs with high sensitivities (high Q s and $GAIN \gg 1$). You must make sure that sensitivities to component variations do not make these designs impractical. A feature in the display allows you to view the f_n and Q sensitivity of filter sections to resistor and capacitor variations.

Using the Sensitivity Display Feature

To use the *Sensitivity* display option, click on the sensitivity radio button in the Settings area of the screen. The schematic shows sensitivity of f_n and Q to each component for each filter section. The format is S^f ; S^Q .

Rather than displaying the derivative with respect to component variations, the program calculates f_n and Q change for a 1% change in component values. This gives a more realistic sensitivity value for real-world variations.

Using the Seed Resistor Setting

The *Seed Resistor* setting allows you to scale the computer-selected resistor values to match the application. Move the cursor to the *Seed Resistor* field and enter your *seed* resistor value. The default value of 10 k Ω is suggested for most applications.

When the circuit is in a power sensitive environment (battery power, solar power, etc.) the value can be increased to decrease power consumption. Some high speed op amps require lower feedback resistance, so their seed resistor value should be decreased.

Higher resistor values, e.g., 100 k Ω , can be used with FET- input op amps. At temperatures below about 70°C, dc errors and excess noise due to op amp input bias current are small. Remember, however, that noise due to the resistors is increased by \sqrt{n} where n is the resistor increase multiplier.

Lower resistor values, e.g., 50 Ω , are a better match for high frequency filters using a wide range of high-speed amplifiers from Texas Instruments.

The seed resistor value is ignored when a capacitor value is entered, as described in the following paragraphs.

Capacitor Values

Compared to resistors, capacitors with tight tolerances are more difficult to obtain and can be much more expensive. The *Capacitor* fields allow you to enter actual measured capacitor values. In this way, an accurate filter response can be achieved with relatively inexpensive components.

Unless capacitor entries are made, *FilterPro* selects capacitors from standard E6 (6 values per decade) values. When values other than E6 are used (E12, measured, etc.), then the appropriate values should be entered.

Using the Capacitor Option

To use the *Capacitor* option, move the cursor to any capacitor field and enter your value. Prompts on the left of the screen advise min/max capacitor entry limits. With each capacitor entry, the program selects exact or closest standard 1% resistor values as before.

Entering capacitor values manually causes the program to ignore the seed resistor value.

Compensate for Op Amp Input Capacitance—Sallen-Key Only

If the common-mode input capacitance of the op amp used in a Sallen-Key filter section is more than approximately $C1/400$ (0.25% of $C1$), it must be considered for accurate filter response. You can use the capacitor entry fields to compensate for op amp input capacitance by simply adding the value of the op amp common-mode input capacitance to the actual value of $C1$. The program then automatically recalculates the exact or closest 1% resistor values for accurate filter response. No compensation for op amp input capacitance is required with MFB designs.

Capacitor Selection

Capacitor selection is very important for a high-performance filter. Capacitor behavior can vary significantly from ideal, introducing series resistance and inductance, which limit Q . Also, nonlinearity of capacitance vs voltage causes distortion.

Common ceramic capacitors with high dielectric constants, such as *high-K* types, can cause errors in filter circuits. Recommended capacitor types are: NPO ceramic, silver mica, metallized polycarbonate; and, for temperatures up to 85°C, polypropylene or polystyrene.

Using the f_n and Q Display

To aid in selection of the op amp, a feature in *FilterPro* allows you to view pole-pair section f_n and Q. The f_n and Q information is also useful when trouble-shooting filters by comparing the expected to the actual response of individual filter sections.

Op Amp Selection

It is important to choose an op amp that can provide the necessary dc precision, noise, distortion, and speed. Texas Instruments offers an excellent selection of op amps that can be used for high performance active filters. The following internet web page provides guides to select an appropriate op amp for your application:

<http://focus.ti.com/docs/analog/analoghomepage.jhtml>

This same page also contains a link to the download page for *FilterPro*.

The following paragraphs define parameters that should be evaluated when selecting op amps for filter circuits.

Op Amp Gain Bandwidth Product (GBP)

In a low-pass filter section, maximum gain peaking is very nearly equal to Q at f_n (the section's natural frequency). So, as a rule of thumb:

For an MFB section: Op amp GBP should be at least $100 \cdot \text{GAIN} \cdot f_n$.

High-Q Sallen-Key sections require higher op amp GBP.

For a Sallen-Key section: For $Q > 1$, op amp GBP should be at least $100 \cdot \text{GAIN} \cdot Q^3 \cdot f_n$. For $Q \geq 1$, op amp GBP should be at least $100 \cdot \text{GAIN} \cdot f_n$.

For a real-pole section: Op amp GBP should be at least $50 \cdot f_n$.

Although Q is formally defined only for complex poles, it is convenient to use a Q of 0.5 for calculating the op amp gain required in a real-pole section.

For example, a unity-gain 20-kHz 5-pole, 3-dB ripple Chebyshev MFB filter with a 2nd pole-pair f_n of 19.35 kHz and a Q of 8.82 needs an op amp with unity gain bandwidth of at least 17 MHz. On the other hand, a 5-pole Butterworth MFB filter, with a worst case Q of 1.62 needs only a 3.2-MHz op amp. The same 5-pole Butterworth filter implemented with a Sallen-Key topology would require a 8.5-MHz op amp in the high-Q section.

Op Amp Slew Rate

For adequate full-power response, the slew rate of the op amp must be greater than $\pi \cdot V_{o,p-p} \cdot \text{FILTER BANDWIDTH}$. For example, a 100-kHz filter with 20-V_{p-p} output requires an op amp slew rate of at least 6.3 V/ms.

Full Power Bandwidth

The full power bandwidth of the op amp should be at least the maximum signal to be passed.

The UAF42 Universal Active Filter

For other filter designs, consider the Texas Instruments UAF42 universal active filter. It can easily be configured for a wide variety of low-pass, high-pass, band-pass, or band-reject (notch) filters. It uses the classical state-variable architecture with an inverting amplifier and two integrators to form a pole-pair. The integrators include on-chip 1000-pF, $\pm 0.5\%$ capacitors. This solves one of the most difficult problems in active filter implementation—obtaining tight tolerance, low-loss capacitors at reasonable cost.

Simple design procedures for the UAF42 allow implementation of Butterworth, Chebyshev, Bessel, and other types of filters. An extra FET-input op amp in the UAF42 can be used to form additional stages or special filter types such as inverse Chebyshev. The UAF42 is available in a standard 14-pin DIP. For more information, request the TI/Burr-Brown product data sheet for the UAF42 and application bulletin AB-035.

Current Feedback Amplifiers

Although it is possible to configure current feedback amplifiers as filters, *neither* the MFB nor the Sallen-Key topologies should be used for a low-pass filter using values defined by FilterPro.

Fully Differential Amplifiers

It is possible to produce good fully balanced filters using the fully differential amplifier in the MFB topology. Both feedback paths of the amplifier should be configured with a matching set of resistors and capacitors. Figure 12 shows an application containing a fully differential amplifier using this method.

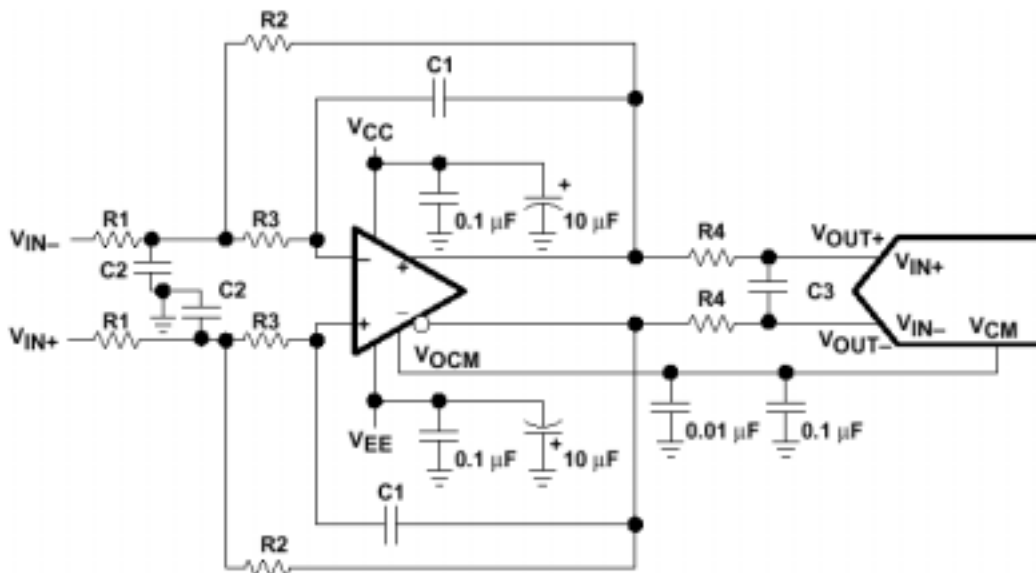

Figure 12. Third-Order Low-Pass Filter Driving an ADC

Examples of MFB Filter Response

Figures 13 and 14 show actual measured magnitude response plots for 5th-order 20-kHz Butterworth, 3-dB Chebyshev and Bessel filters designed with the program. The op amp used in all filters was the OPA627. As can be seen in Figure 13, the initial rolloff of the Chebyshev filter is fastest and the rolloff of the Bessel filter is the slowest. However, each of the 5th-order filters ultimately rolls off at $-N \cdot 20\text{dB/decade}$, where N is the filter order (-100 dB/decade for a 5-pole filter).

The oscilloscope photographs (Figures 15-17) show the step response for each filter. As expected, the Chebyshev filter has the most ringing, while the Bessel has the least. Figure 18 shows distortion plots vs frequency for the three filters. See application bulletin AB-017 for measured Sallen-Key filter performance of the same three designs.

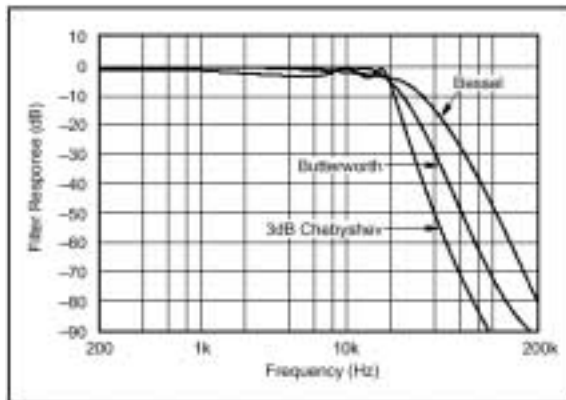

Figure 13. Gain vs Frequency for Fifth-Order 20kHz Butterworth, Chebyshev, and Bessel Unity-Gain MFB Low-Pass Filters, Showing Overall Filter Response.

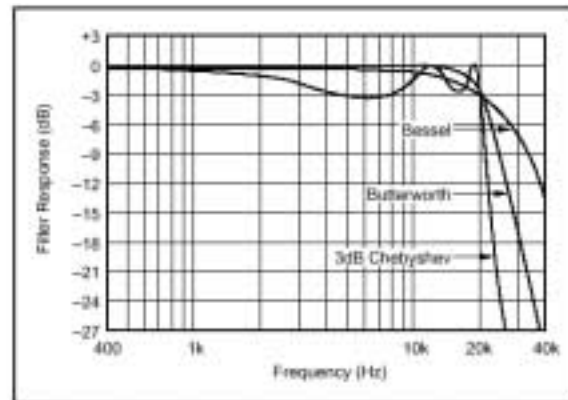

Figure 14. Gain vs Frequency for Fifth-Order 20kHz Butterworth, Chebyshev, and Bessel Unity-Gain MFB Low-Pass Filters, Showing Transition-Band Detail.

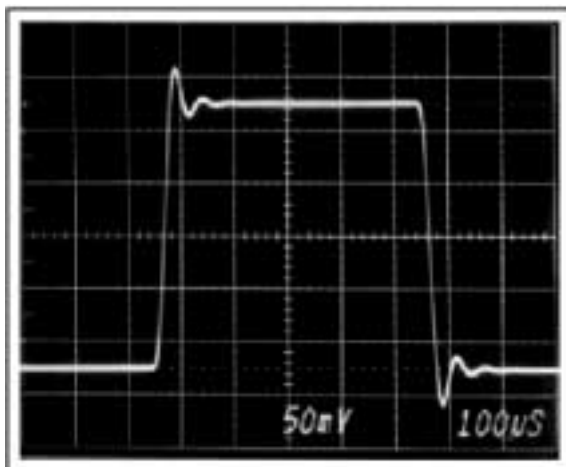

Figure 15. Step Response of Fifth-Order 20 kHz Butterworth Low-Pass MFB Filter.

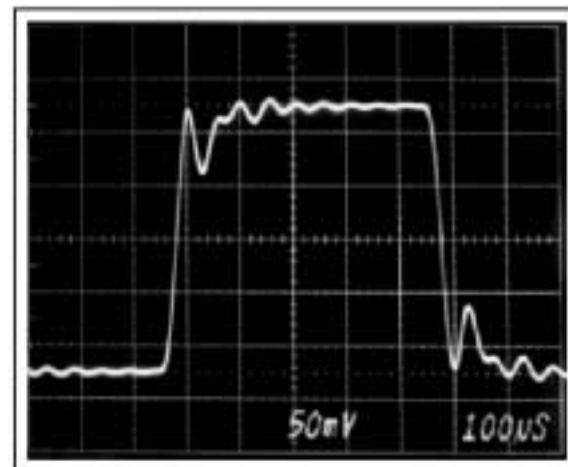

Figure 16. Step Response of Fifth-Order 20 kHz Chebyshev Low-Pass MFB Filter.

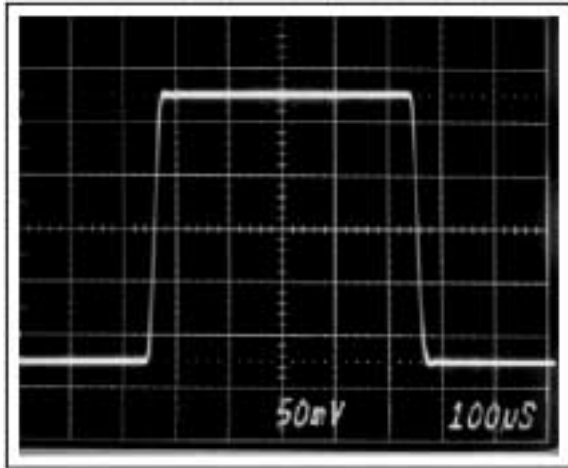

Figure 17. Step Response of Fifth-Order 20 kHz Bessel Low-Pass MFB Filter.

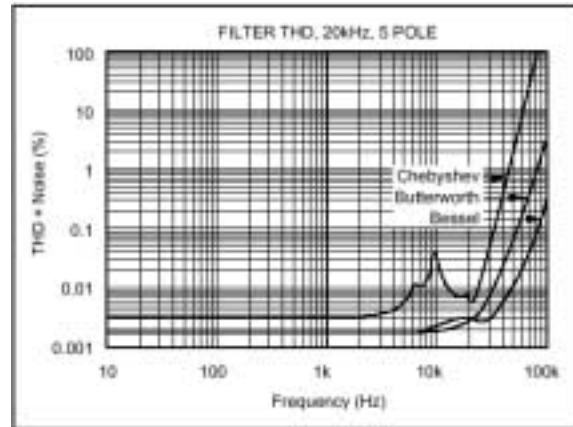

Figure 18. Measured Distortion for the Three 20 kHz MFB Low-Pass Filters.

Conclusion

Using FilterPro, the designer can develop low-pass filters for many different applications without the need for complex calculations.

IMPORTANT NOTICE

Texas Instruments Incorporated and its subsidiaries (TI) reserve the right to make corrections, modifications, enhancements, improvements, and other changes to its products and services at any time and to discontinue any product or service without notice. Customers should obtain the latest relevant information before placing orders and should verify that such information is current and complete. All products are sold subject to TI's terms and conditions of sale supplied at the time of order acknowledgment.

TI warrants performance of its hardware products to the specifications applicable at the time of sale in accordance with TI's standard warranty. Testing and other quality control techniques are used to the extent TI deems necessary to support this warranty. Except where mandated by government requirements, testing of all parameters of each product is not necessarily performed.

TI assumes no liability for applications assistance or customer product design. Customers are responsible for their products and applications using TI components. To minimize the risks associated with customer products and applications, customers should provide adequate design and operating safeguards.

TI does not warrant or represent that any license, either express or implied, is granted under any TI patent right, copyright, mask work right, or other TI intellectual property right relating to any combination, machine, or process in which TI products or services are used. Information published by TI regarding third-party products or services does not constitute a license from TI to use such products or services or a warranty or endorsement thereof. Use of such information may require a license from a third party under the patents or other intellectual property of the third party, or a license from TI under the patents or other intellectual property of TI.

Reproduction of information in TI data books or data sheets is permissible only if reproduction is without alteration and is accompanied by all associated warranties, conditions, limitations, and notices. Reproduction of this information with alteration is an unfair and deceptive business practice. TI is not responsible or liable for such altered documentation.

Resale of TI products or services with statements different from or beyond the parameters stated by TI for that product or service voids all express and any implied warranties for the associated TI product or service and is an unfair and deceptive business practice. TI is not responsible or liable for any such statements.

Mailing Address:

Texas Instruments
Post Office Box 655303
Dallas, Texas 75265